

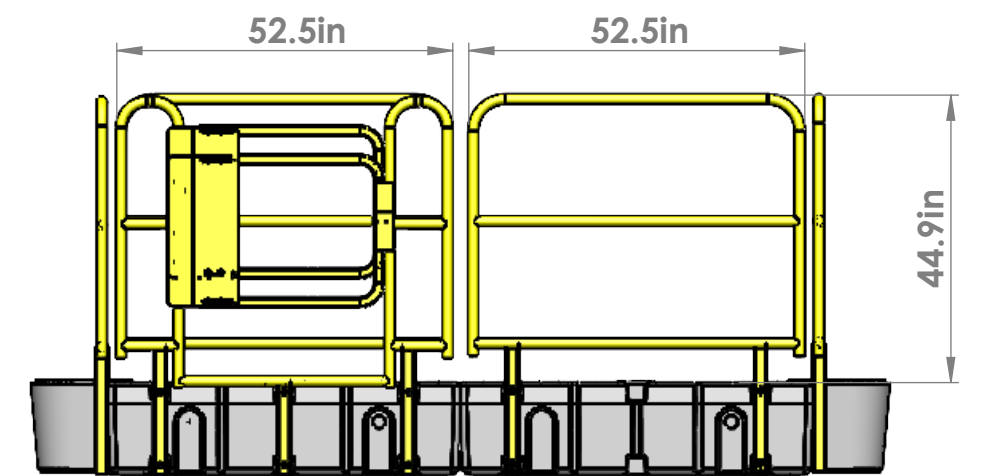

DETAIL A
SCALE 2 : 25

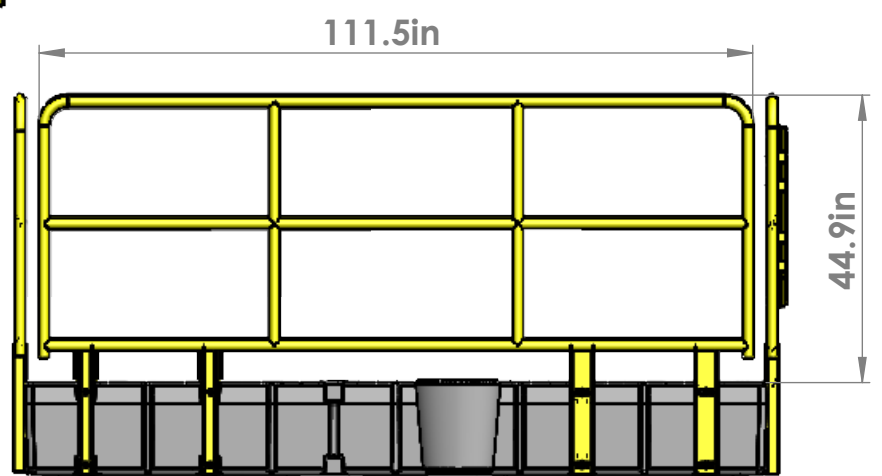
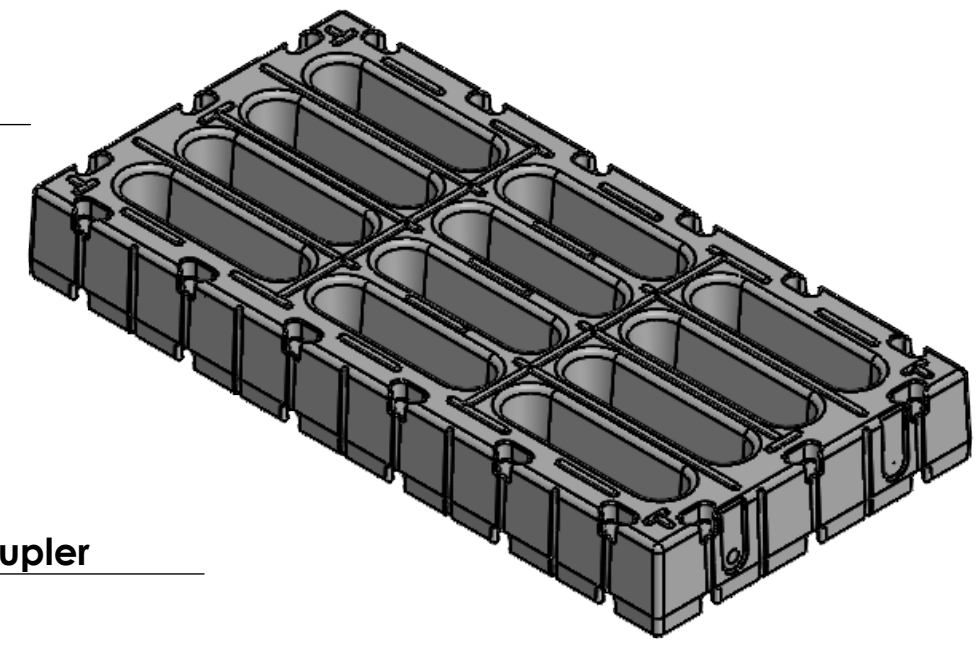

NOTES:

1. Without Handrails and any load, Platform will be around 12.5" out of water.
2. Full Capacity of the platform (at 100% submersion) is 6300 lbs.

NOT IN SCALE	DRAWN BY	DATE		TITLE:	REVISION
STATUS: RELEASED	AB	01/31/2023		10 Ft. x 10 Ft. Work Platform	SHEET 1 OF 1
SNAP DOCK PRODUCTS			TOLERANCES	PART NO.	ENG. ID.
<small>ALL DIMENSIONS, DESIGNS, AND INFORMATION ON THIS PRINT MUST BE CONSIDERED PROPRIETARY TO SNAP DOCK PRODUCTS AND MAY NOT BE USED, COPIED, OR DISTRIBUTED WITHOUT WRITTEN PERMISSION OF AN OFFICER (OR HIS AGENT) OF THE FIRM.</small>			<small>ANGULAR = LINEAR =</small>		Illustration of Platform